



INSTALLATION AND OPERATION MANUAL

Solar kit for air to water heat pump system

EKSOLHWAVJU

EKHW*050+080*

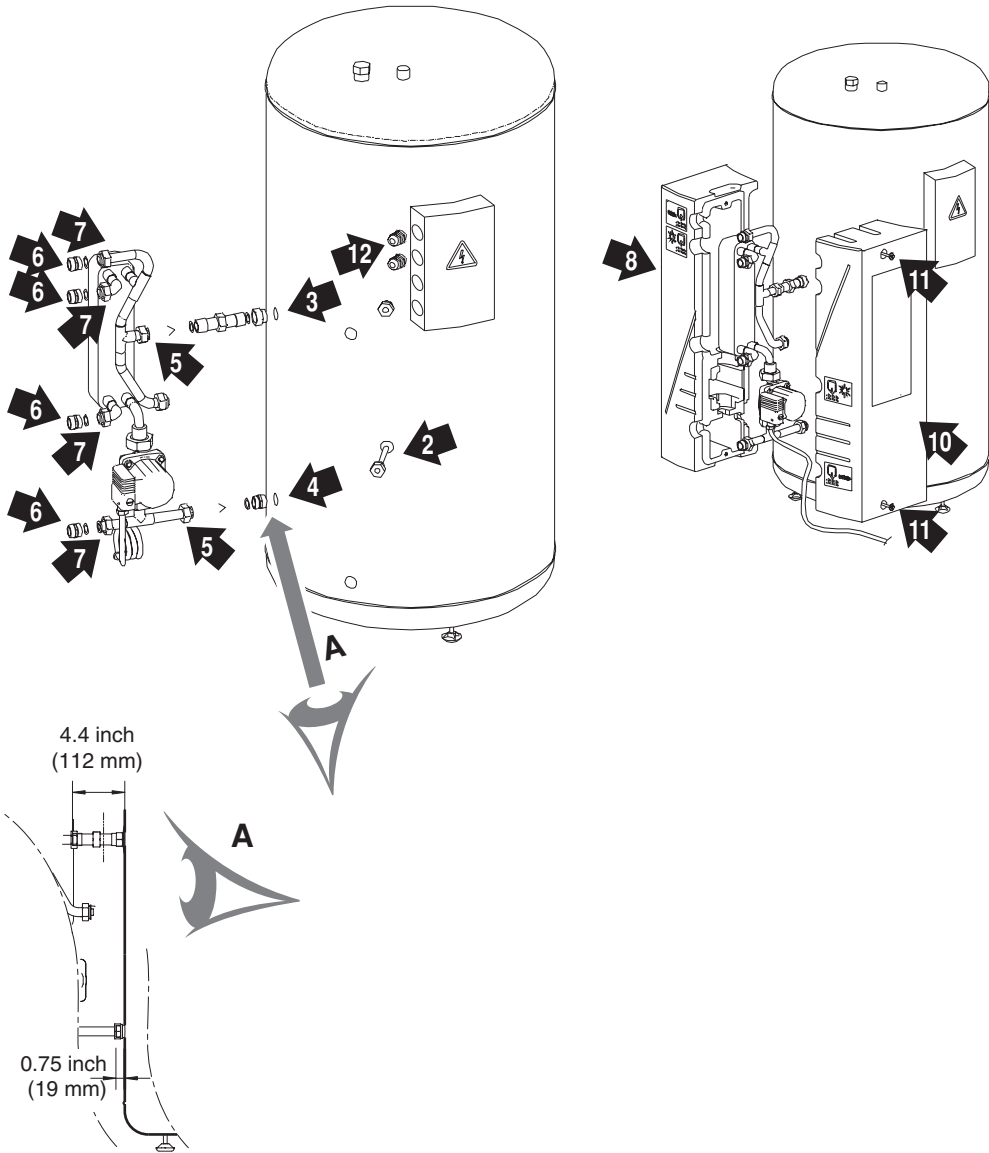

CONTENTS

	Page
Introduction.....	1
General information.....	1
Scope of this manual.....	1
Model identification	2
Safety considerations	2
General system setup and operation.....	3
General system setup	3
Requirements and recommendations concerning field supplied solar panels and solar pump station	3
Accessories	5
Accessories supplied with the solar kit.....	5
Overview of the solar kit	5
Main components.....	5
Installation of the solar kit	6
Selecting an installation location	6
Dimensions and service space	6
Installation guidelines	6
Installing the solar kit.....	6
Field wiring	8
Start up	12
Operating instructions.....	12
Configuring your system	12
Troubleshooting and servicing	14
General guidelines	14
General symptoms	14
Error codes.....	14
Disposal requirements.....	14
Technical specifications	15
Annexes.....	15
Decision flow of heating the domestic water by heat pump or by solar kit.....	15
Decision flow of heating the domestic water by booster heater	16



READ THESE INSTRUCTIONS CAREFULLY BEFORE INSTALLATION. KEEP THIS MANUAL IN A HANDY PLACE FOR FUTURE REFERENCE.

IMPROPER INSTALLATION OR ATTACHMENT OF EQUIPMENT OR ACCESSORIES COULD RESULT IN ELECTRIC SHOCK, SHORT-CIRCUIT, LEAKS, FIRE OR OTHER DAMAGE TO THE EQUIPMENT. BE SURE ONLY TO USE ACCESSORIES MADE BY DAIKIN WHICH ARE SPECIFICALLY DESIGNED FOR USE WITH THE EQUIPMENT AND HAVE THEM INSTALLED BY A PROFESSIONAL.

ALL ACTIVITIES DESCRIBED IN THIS MANUAL SHALL BE CARRIED OUT BY A LICENSED TECHNICIAN.

BE SURE TO WEAR ADEQUATE PERSONAL PROTECTION EQUIPMENT (PROTECTION GLOVES, SAFETY GLASSES, ...) WHEN PERFORMING INSTALLATION, MAINTENANCE OR SERVICE TO THE UNIT.

IF UNSURE OF INSTALLATION PROCEDURES OR USE, ALWAYS CONTACT YOUR DAIKIN DEALER FOR ADVICE AND INFORMATION.

THE UNIT DESCRIBED IN THIS MANUAL IS DESIGNED FOR INDOOR INSTALLATION ONLY AND FOR AMBIENT TEMPERATURES RANGING 39°F~95°F (4°C~35°C).

The English text is the original instruction. Other languages are translations of the original instructions.

This appliance is not intended for use by persons, including children, with reduced physical, sensory or mental capabilities, or lack of experience and knowledge, unless they have been given supervision or instruction concerning use of the appliance by a person responsible for their safety.

Children should be supervised to ensure that they do not play with the appliance.



Before operating the unit, make sure the installation has been carried out correctly by a professional Daikin dealer.

If you feel unsure about operation, contact your Daikin dealer for advice and information.

INTRODUCTION

General information

The solar kit must be installed by a licensed technician and in compliance with the instructions in this manual.

The solar kit is to be connected to the EKHW* domestic hot water tank.

The solar kit will enable you to heat up your domestic water by means of the sun whenever the sun is available.

To get the most comfort and energy savings out of your system, make sure to observe the section "Configuring your system" on page 12 of this manual.

Scope of this manual

This installation manual describes the procedures for installing and operating the EKSOLHWAVJU solar kit.

Model identification

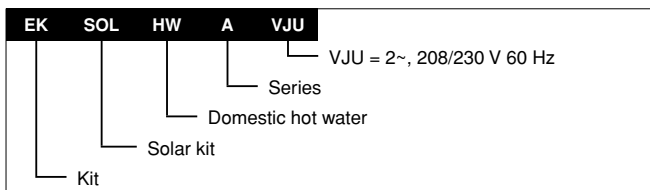

SAFETY CONSIDERATIONS

The precautions listed here are divided into the following four types. They all cover very important topics, so be sure to follow them carefully.

Meanings of **DANGER**, **WARNING**, **CAUTION** and **NOTE** symbols.



DANGER

Indicates an imminently hazardous situation which, if not avoided, will result in death or serious injury.

WARNING

Indicates a potentially hazardous situation which, if not avoided, could result in death or serious injury.

CAUTION

Indicates a potentially hazardous situation which, if not avoided, may result in minor or moderate injury. It may also be used to alert against unsafe practices.

NOTE

Indicates situations that may result in equipment or property-damage accidents only.

Danger

- Before touching electric terminal parts, turn off power switch.
- When service panels are removed, live parts can be easily touched by accident.
Never leave the unit unattended during installation or servicing when the service panel is removed.
- Do not touch water pipes during and immediately after operation as the pipes may be hot. Your hand may suffer burns. To avoid injury, give the piping time to return to normal temperature or be sure to wear proper gloves.
- Do not touch any switch with wet fingers. Touching a switch with wet fingers can cause electrical shock.
- Before touching electrical parts, turn off all applicable power supply.

Warning

- Tear apart and throw away plastic packaging bags so that children will not play with them.
Children playing with plastic bags face danger of death by suffocation.
- Safely dispose of packing materials. Packing materials, such as nails and other metal or wooden parts, may cause stabs or other injuries.
- The piping between solar panels, solar pump station and solar kit shall be copper piping and properly insulated. The piping can reach the same temperature as the maximum allowable solar panel temperature.
- The piping between heating circuit and solar kit connection shall be copper piping, at least 1.64 ft (0.5 m) long and properly insulated.
Due to heat conduction, the piping can become very hot.

- Do not touch the internal parts (pump, etc.) during and immediately after operation.
Your hands may suffer burns if you touch the internal parts. To avoid injury, give the internal parts time to return to normal temperature or, if you must touch them, be sure to wear proper gloves.
- Make certain that all electrical work is carried out by qualified personnel according to the local laws and regulations and this installation manual, using a separate circuit.
Insufficient capacity of the power supply circuit or improper electrical construction may lead to electric shocks or fire.
- Make sure that all wiring is secure, using the specified wires and ensuring that external forces do not act on the terminal connections or wires.
Incomplete connection or fixing may cause a fire.

Caution

- Ground the unit.
Grounding resistance should be according to local laws and regulations.
Do not connect the ground wire to gas or water pipes, lightning conductor or telephone ground wire.
Incomplete grounding may cause electric shocks.
- Gas pipe.
Ignition or explosion may occur if the gas leaks.
- Water pipe.
Hard vinyl tubes are not effective grounds.
- Lightning conductor or telephone ground wire.
Electric potential may rise abnormally if struck by a lightning bolt.
- Install the power wire at least 3.28 ft (1 meter) away from televisions or radios to prevent image interference or noise.
(Depending on the radio waves, a distance of 3.28 ft (1 meter) may not be sufficient to eliminate the noise.)
- Do not rinse the unit. This may cause electric shocks or fire.
- Do not install the unit in places such as the following:
 - Where there is mist of mineral oil, oil spray or vapour.
Plastic parts may deteriorate, and cause them to fall out or water to leak.
 - Where corrosive gas, such as sulphurous acid gas, is produced.
Corrosion of copper pipes or soldered parts may cause water to leak.
 - Where there is machinery which emits electromagnetic waves.
Electromagnetic waves may disturb the control system, and cause malfunction of the equipment.
 - Where flammable gases may leak, where carbon fibre or ignitable dust is suspended in the air or where volatile flammables, such as thinner or gasoline, are handled.
Such gases may cause a fire.
 - Where the air contains high levels of salt.
 - Where voltage fluctuates a lot, such as that in factories.
 - In vehicles or vessels.
 - Where acidic or alkaline vapour is present.



GENERAL SYSTEM SETUP AND OPERATION

General system setup

The solar kit is designed to transfer the heat from the solar panels to the heat exchanger of the domestic hot water tank EKHV* and is to be installed in the system as shown in the scheme below.

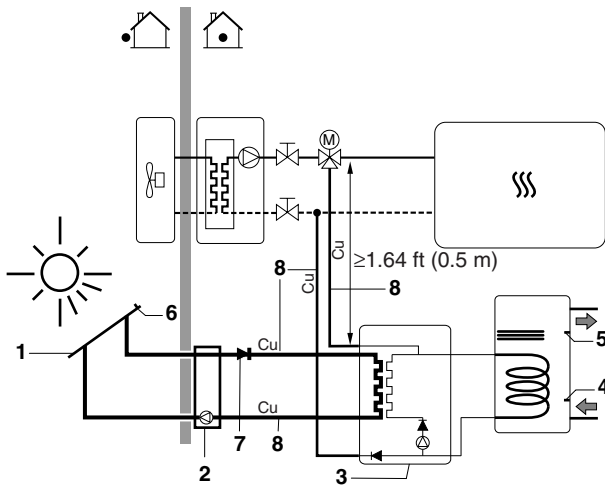

- 1 Solar panels (field supply)
 - 2 Solar pump station (field supply)
 - 3 Solar kit
 - 4 Domestic hot water temperature sensor of the solar pump station (field supply)
 - 5 Domestic hot water temperature sensor of the indoor unit
 - 6 Solar panel temperature sensor (field supply)
 - 7 Non-return valve (to be included in solar pump station or to be installed in field piping)
 - 8 The piping between heating circuit and solar kit connection shall be copper piping and properly insulated to avoid possible injuries.
- ☺ Heating system.
Refer to the indoor unit installation manual.

The solar panels (1) catch the heat of the sun. When the temperature of the glycol solution in the solar panel has become higher than the water temperature in the domestic hot water tank, the pump of the solar pump station (2) and the pump of the solar kit (3) start to operate as to transfer the heat to the heat exchanger of the domestic hot water tank, unless priority is given to the heat pump. Refer to "Operating instructions" on page 12 (subsection: Configuring your system).

Requirements and recommendations concerning field supplied solar panels and solar pump station



CAUTION

Solar panel

Appropriate selection is to be made by your solar panel supplier, in accordance with local laws and regulations.

Solar pump station

The solar pump station must meet following requirements:

Electrical connection

The solar pump station will have an auxiliary contact that closes when the contact for the pump of the solar pump station is operated.

This contact will provide the input towards the indoor unit, and prevent domestic water heating by the heat pump and/or booster heater during solar heating.

For wiring examples, refer to the following drawings.

Example

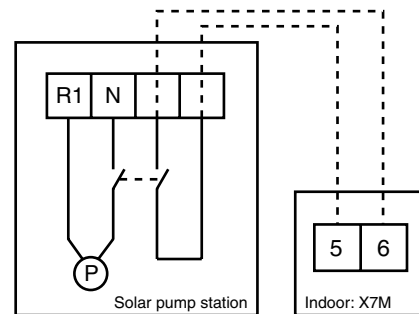

----- Field wiring
 Solar pump station Solar pump station
 Indoor: X7M Indoor: X7M

Settings

■ Maximum solar panel temperature

If the temperature of the solar panel is above this value, the solar pump station will stop or not resume pump operation.

This setting will have a fixed value **equal to or below 212°F (100°C)**, or it will be possible to put this value equal to or below 212°F (100°C).



WARNING

- The piping between solar panels, solar pump station and solar kit shall be copper piping and properly insulated. The piping can reach the same temperature as the maximum allowable solar panel temperature.
- The piping between heating circuit and solar kit connection shall be copper piping, at least 1.64 ft (0.5 m) long and properly insulated. Due to heat conduction, the piping can become very hot.
- As the piping can become warmer than 123°F (51°C), all piping shall be properly insulated to avoid any possible (injury) burn.
- All used parts shall withstand the minimum technical specifications mentioned under "Technical specifications" on page 15.

NOTE  Putting this value to a higher value can break down the pump of the solar pump station.

Also refer to the eye-catcher caution label that was torn up when unpacking the installation manual.

Limiting the maximum solar panel temperature to 212°F (100°C) however, can affect efficiency of the solar panel.

But on the other hand:

- as it is important for reliability of the pump in the solar pump station only that temperature of the return water to that solar pump is lower than 212°F (100°C);
- and in case the 212°F (100°C) limit for the return water temperature to the solar pump can be guaranteed by other means than by limiting the 'Maximum solar panel temperature';

then the value of the 'Maximum solar panel temperature' can be set to a higher temperature.

Please contact your local solar panel dealer.

■ **ON/OFF/AUTO**

If the solar pump station has an ON/OFF/AUTO function, make sure to put it on the AUTO function. This means that the pump will switch on automatically when the solar panel temperature rises sufficiently above the domestic hot water tank temperature and switch off automatically when the difference between the solar panel and the domestic hot water tank temperature becomes too low.

■ **Maximum tank temperature**

When the maximum temperature of the domestic hot water tank is reached, the solar pump station will stop pump operation.



CAUTION

- Do not put this value above 176°F (80°C) to avoid overheating of the domestic hot water tank and to avoid activation of the booster heater thermal protector in the domestic hot water tank.
- Some solar pump stations provide the possibility to still dump heat to the domestic hot water tank, even when the maximum domestic hot water tank temperature is already reached. This to reduce the solar panel temperature by circulating the solar panel fluid and transfer the heat to the domestic hot water tank.

If this function is present, it should be put to OFF as to avoid thermal cut out operation of the tank.



You can also change the domestic hot water temperature setpoint on the controller of the indoor unit. Refer to the operation manual of the indoor unit. This temperature is sensed by the domestic hot water temperature sensor of the indoor unit, located in the upper thermistor holder of the domestic hot water tank. For reasons of energy savings, it is advised to put this temperature as low as possible without compromising the required supply of hot water.

This setting preferably is lower than the maximum tank temperature setting on the controller of the solar pump station.

The maximum temperature that can be set in the controller of the solar pump station is sensed by the domestic hot water temperature sensor of the solar pump station, located in the lower thermistor holder of the domestic hot water tank.

Refer also to "[Operating instructions](#)" on page 12 (subsection: [Configuring your system](#)).



WARNING

If this water temperature (domestic hot water tank) can be a potential risk for human injuries, a mixing valve (field supply) shall be installed at the hot water outlet connection of the domestic hot water tank. This mixing valve shall secure that the hot water temperature at the hot water tap never rise above a set maximum value. This maximum allowable hot water temperature shall be selected according to local laws and regulations.

- **Minimum temperature difference between domestic hot water tank and solar panel before starting pump operation**

This minimum temperature difference will be put equal to or above 18°F (10°C).

- **Anti-freeze setting**

Some solar pump stations have an anti-freeze function. If the solar panel temperature becomes too low, such solar pump stations will circulate the solar fluid as to extract heat from the tank and to avoid freezing of the solar fluid.

Make sure to disable this function.

NOTE



Make sure the concentration of glycol in the solar panel is big enough as to avoid freezing of the glycol at all times.

Hydraulic connection

Make sure the solar pump station has non-return valves as to avoid thermosiphon effect (migration of hot water to cold places). If the solar pump station has no hydraulic connections included, install them in the field piping as shown in "[General system setup](#)" on page 3.

ACCESSORIES

Accessories supplied with the solar kit

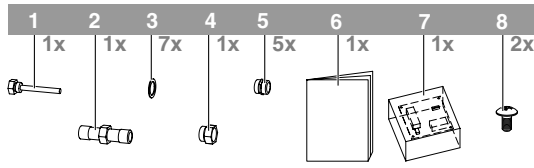

	Quantity	Necessary accessory for installation of the solar kit for each type of domestic hot water tank	
		EKHWS	
		050 50 gallons (200 l)	080 80 gallons (300 l)
1 Thermistor socket 1/2" Male BSP (internal diameter 6.1)	1	1	1
2 Connection pipe 3/4" Male BSP x 3/4" Male BSP	1	1	1
3 Sealing	7	7	7
4 Adaptor 3/4" Female BSP x 3/4" Male BSP	1	1	1
5 Adaptor 3/4" Male BSP x 3/4" Male BSP	5	5	5
6 Installation manual	1	1	1
7 EKR1HB Digital I/O PCB kit	1	1	1
8 Contactor fixing screw	2	2	2

OVERVIEW OF THE SOLAR KIT

Main components

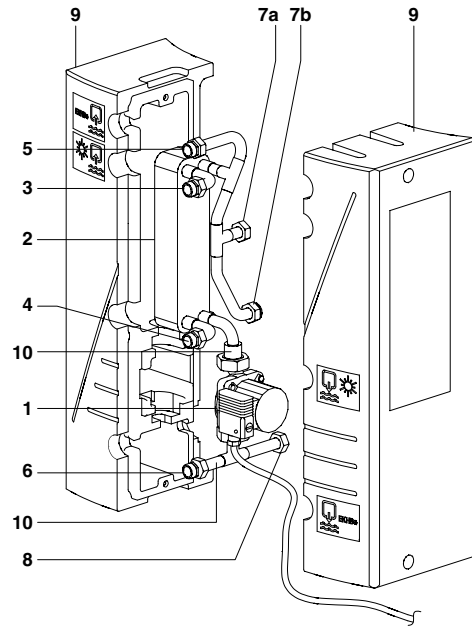

- 1 Solar kit circulation pump
- 2 Heat exchanger
- 3 Inlet connection from solar pump station
- 4 Return connection to solar pump station
- 5 Inlet connection from the indoor unit
- 6 Return connection to the indoor unit
- 7a Return connection to the 50 and 80 gallons (200 and 300 l) domestic hot water tank heat exchanger
- 7b Not applicable
- 8 Inlet connection from the domestic hot water tank heat exchanger
- 9 EPP casing
- 10 Non-return valves

Safety functions

Thermal cut out

The solar kit is electrically connected with the thermal cut out safety of the domestic hot water tank. (refer to "Field wiring" on page 8).

When the thermal cut out safety of the domestic hot water trips, the power supply to the pump of the solar kit is interrupted so that no more solar heat can be transferred to the domestic hot water tank.

INSTALLATION OF THE SOLAR KIT

Selecting an installation location

- The solar kit is to be installed in a frost free indoor space, directly connected to the domestic hot water tank.
- Make sure the service space is available as indicated in below drawing.
- The space around the unit has to allow sufficient air circulation.
- It shall be made sure that in the case of a leak, leaking water will not cause any damage or unsafe situations.
- Do not install or operate the unit in rooms mentioned below:
 - Where corrosive gas like sulphurous gas exists: copper tubing and brazed spots may corrode.
 - Where volatile flammable gas like thinner or gasoline is used.
 - Where machines generating electromagnetic waves exist: the control system may malfunction.
 - Where the air contains high levels of salt such as air near the ocean and where voltage fluctuates a lot (e.g. in factories). This applies also to vehicles or vessels.

Dimensions and service space

Service space dimensions below relate to requirements for installation of the solar kit only.
For service space dimensions of the domestic hot water tank, refer to the domestic hot water tank installation manual.

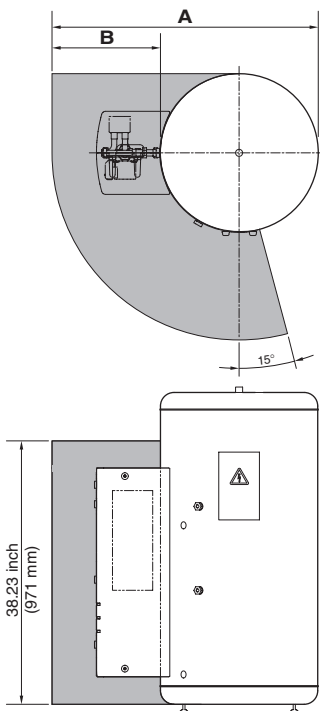

	A	B
EKHWS050 (50 gallons)(200 l)	38.58 inch (980 mm)	15.75 inch (400 mm)
EKHWS080 (80 gallons)(300 l)		

Installation guidelines



WARNING

Make sure that all the piping to the solar kit is insulated.



CAUTION

- Make sure that all the piping to the solar kit is sufficiently supported so that it will not cause any stress on the solar kit.
- Make sure the piping is protected against dirt during installation. Dirt in the piping might clog the heat exchanger of the solar panel and reduce its performance.



NOTE

Make sure that the piping coming from outdoors to the solar kit is put through the wall under an angle and the wall hole is sufficiently sealed afterwards, so no water can enter the space.

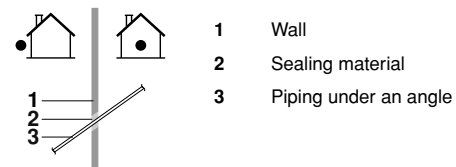

Installing the solar kit

- At delivery, the unit should be checked and any damage should be reported immediately to the carrier claims agent.
- Check if all unit's accessories are enclosed. Refer to "[Accessories supplied with the solar kit](#)" on page 5.
- Bring the unit as close as possible to its final installation position in its original package in order to prevent damage during transport.

Procedure

Refer to [figure 1](#). The numbers on the figure refer to the steps described below.

- 1 Locate the domestic hot water tank in a suitable position to facilitate the installation of the solar kit. It is therefore recommended to first read the entire installation procedure. Refer to the installation guidelines in the installation manual of the domestic hot water tank.

2 Fitting the thermistor sockets

Fit the thermistor socket in the thermistor hole for the domestic hot water temperature sensor of the solar pump station. (Refer to ["Accessories supplied with the solar kit" on page 5, part 1](#)).

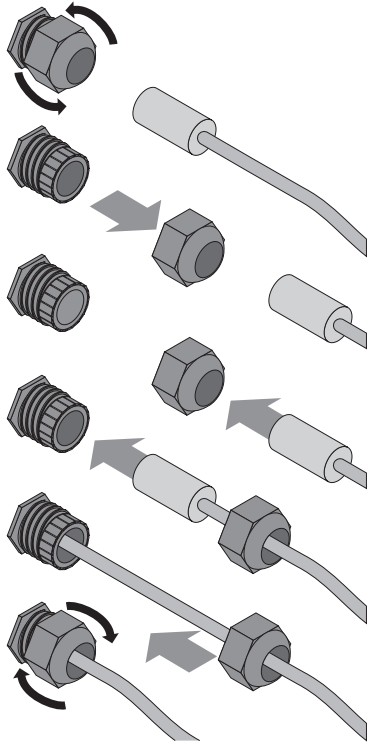

3 Refer to the corresponding sub-step.

3.1 Fit the adaptor 3/4" Female BSP x 3/4" Male BSP in the flow inlet connection of the domestic hot water tank. Refer to ["Accessories supplied with the solar kit" on page 5, part 4](#).

3.2 Fit the connection pipe 3/4" Male BSP x 3/4" Male BSP and sealing in the flow inlet connection of the domestic hot water tank. Refer to ["Accessories supplied with the solar kit" on page 5, part 2 and 3](#).

4 Fit the adaptor 3/4" Male BSP x 3/4" Male BSP in the heat exchanger outlet connection of the domestic hot water tank. Refer to ["Accessories supplied with the solar kit" on page 5, part 5](#).

5 Fit the solar kit and sealings (x2) on the heat exchanger inlet connection and heat exchanger outlet connection of the domestic hot water tank. Torque 3.69 lb•ft (5 N•m). Refer to ["Accessories supplied with the solar kit" on page 5, part 3](#).

6 Fit the adaptors 3/4" Male BSP x 3/4" Male BSP (x4) to the field piping:

- Inlet connection from indoor unit.
- Return connection to indoor unit.
- Inlet connection from solar pump station.
- Return connection to solar pump station.

Refer to ["Accessories supplied with the solar kit" on page 5, part 5](#).



WARNING

- The piping between solar panels, solar pump station and solar kit shall be copper piping and properly insulated. The piping can reach the same temperature as the maximum allowable solar panel temperature.
- The piping between heating circuit and solar kit connection shall be copper piping, at least 1.64 ft (0.5 m) long and properly insulated. Due to heat conduction, the piping can become very hot.
- As the piping can become warmer than 123°F (51°C), all piping shall be properly insulated to avoid any possible (injury) burn.
- All used parts shall withstand the minimum technical specifications mentioned under ["Technical specifications" on page 15](#).

7 Fit the solar kit and sealings (x4) to the field piping. Torque 3.69 lb•ft (5 N•m). Refer to ["Accessories supplied with the solar kit" on page 5, part 3](#).

8 Mount the left side of the EPP casing onto the solar kit.

9 Mount the EPP lid onto the right side of the EPP casing.

10 Mount the right side of the EPP casing onto the solar kit.

Take care, that the pump cable is routed via the holes in the bottom of the EPP casing.



CAUTION

Ensure that the pump cable cannot come into contact with piping below the pump when cable is routed out.

- 11 Use the screws and washers (x2) to fix the EPP casing. Screw until tight position.

NOTE



Do not switch inlet and outlet connections.

Refer to the chapter "Typical application examples" described in the installation manual delivered with the indoor unit for details on connecting the water circuits and the motorised 3-way valve.



CAUTION

- To install adequate connections between the indoor unit and the solar kit, it is important that the 3-way valve is fitted correctly.
- Ensure that the water piping connected to the solar kit coming from the solar panel and the indoor unit are sufficiently supported and do not cause any stress on the solar kit.

Charging water

Charge the water on the indoor unit and the tank (refer to the installation manuals of the indoor unit and the domestic hot water tank).

Charge the solar panel circuit with a glycol solution.



Observe the instructions as given by your solar panel supplier. Make sure to use non-toxic glycol.



WARNING

ETHYLENE GLYCOL IS TOXIC



Caution: Use of glycol

- Use only propylene glycol having a toxicity rating or class of 1, as listed in "Clinical Toxicology of Commercial Products, 5th edition" may be used.
- In case of over-pressure, be sure to connect the safety valve to a drain in order to recover the glycol.



Corrosion of the system due to presence of glycol

Uninhibited glycol will turn acidic under the influence of oxygen. This process is accelerated by presence of copper and at higher temperatures. The acidic uninhibited glycol attacks metal surfaces and forms galvanic corrosion cells that cause severe damage to the system.

It is therefore of extreme importance:

- that the water treatment is correctly executed by a qualified water specialist;
- that a glycol with corrosion inhibitors is selected to counteract acids formed by the oxidation of glycols;
- only the use of propylene glycol is allowed.
- that no automotive glycol is used because their corrosion inhibitors have a limited lifetime and contain silicates which can foul or plug the system;
- that galvanized piping is not used in glycol systems since its presence may lead to the precipitation of certain components in the glycol's corrosion inhibitor;
- that it has to be made sure the glycol is compatible with the used materials in the system.

NOTE



Be aware of the hygroscopic property of glycol: it absorbs moisture from its environment.

Leaving the cap off the glycol container causes the concentration of water to increase. The glycol concentration is then lower than assumed. And in consequence, freezing can happen after all.

Preventive actions must be taken to ensure minimal exposure of the glycol to air.

Field wiring



WARNING

- Switch off the power supply (outdoor unit power supply, backup heater, and booster heater power supply) before making any connections.
 - All field wiring and components must be installed by a licensed electrician and must comply with local laws and regulations.
 - The field wiring must be carried out in accordance with the wiring diagram and the instructions given below.
 - Use only copper wires.
 - Never squeeze bundled cables and make sure that it does not come in contact with the piping and sharp edges.
- Make sure no external pressure is applied to the terminal connections.
- Be sure to install the required fuses or circuit breakers.
 - After finishing the electrical work, confirm that each electric part and terminal inside the electric part box is connected securely.



CAUTION

Select all cables and wire sizes in accordance with relevant local laws and regulations.

Overview

The illustration below gives an overview of the required field wiring between several parts of the installation. Refer also the wiring diagram, the installation manual of the indoor unit and the domestic hot water tank.

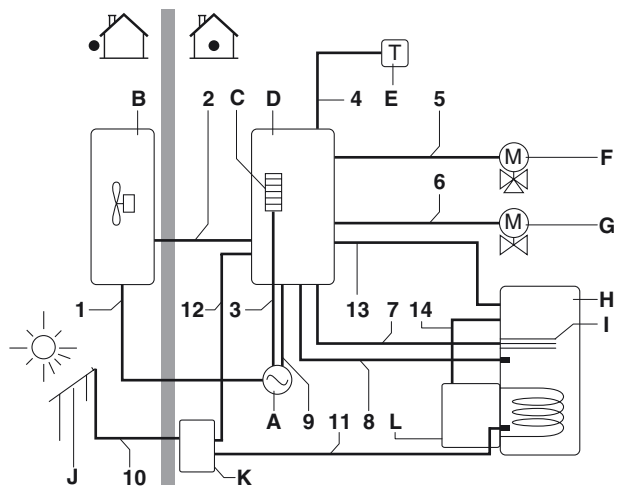

- A...I Refer to the indoor unit installation manual
- J Solar panel
- K Solar pump station
- L Solar kit

Item	Description	Required number of conductors	Maximum running current
1 ... 9	Refer to the installation manual of the indoor unit		
10	Solar panel sensor cable (Field supply with solar pump station)	2	—
11	Domestic hot water temperature sensor of the solar pump station (Field supply)	2	—

Item	Description	Required number of conductors		Maximum running current
12	Operating signal cable from solar pump station to indoor unit (Field supply)		2	1 A
13	Power supply cable from indoor unit to tank (Field supply)	EKHWS	2 ^(a)	1 A
14	Power supply cable from solar kit to tank		2 + GND	1 A

(a) Minimum cable section: AWG18 (0.75 mm²)

Installing the EKR1HB in the indoor unit

Install the PCB delivered with the solar kit in the indoor unit.

Refer to "Accessories supplied with the solar kit" on page 5, part 7.

- 1 Open the EKR1HB box.

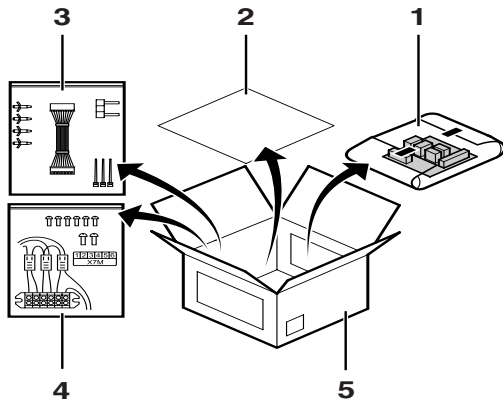

- 1 Wrapped PCB (digital I/O PCB)
- 2 Installation manual
- 3 Accessory bag (connectors)
- 4 Accessory bag (terminal - relays)
- 5 EKR1HB box

- 2 Take out the PCB and unwrap it.
- 3 Open the accessories bag and take the connector labelled X1A.
- 4 Place this connector on the EKR1HB PCB (on the connector X1A/CN1).

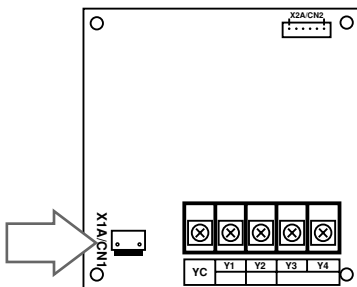

- 5 Mount the plastic raisers from the accessories bag on the indoor EKHB switch box backplate.

- 6 Mount the EKR1HB PCB on the plastic raisers.

Mount the control cable (from the accessories bag) between A1P: X33A (the main PCB) and A4P: X2A/CN2 (the EKR1HB PCB).

■ For EXHBH/X units only

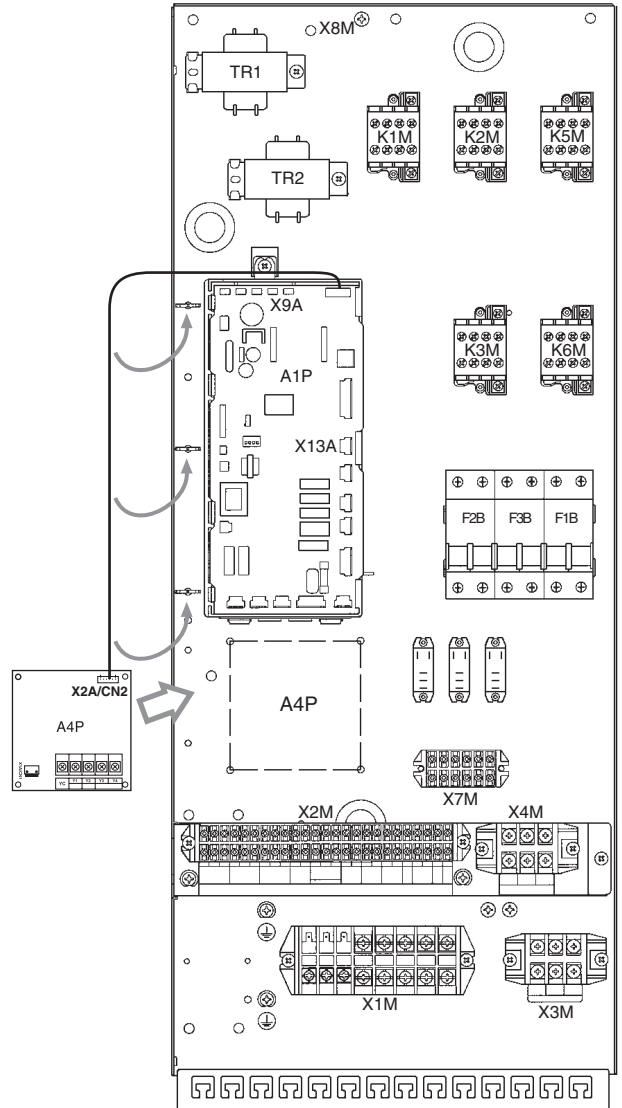

■ For EDH, EBH, EDL, EBL units only

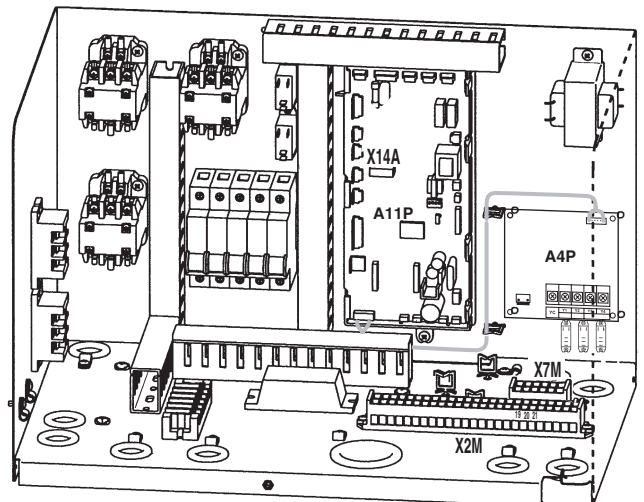

Connecting the temperature sensors

- 1 Mount the solar panel sensor of the solar pump station in the solar panel according to the instructions of the solar pump station and solar panel supplier.
- 2 Mounting the domestic hot water temperature sensor of the solar pump station
Mount the domestic hot water temperature sensor of the solar pump station in the lower sensor holder of the domestic hot water tank.
Insert the sensor as deep as possible in the holder and use thermal paste.

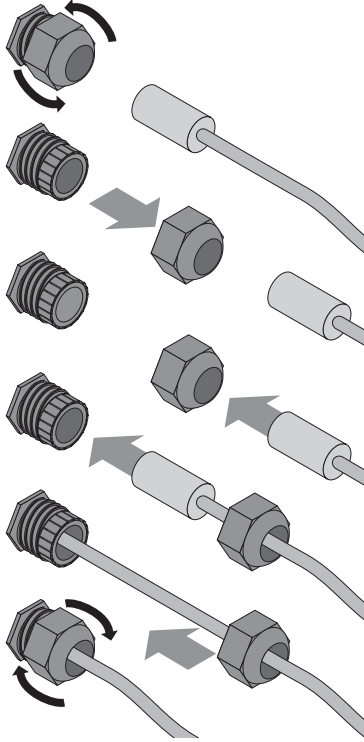

NOTE



- The domestic hot water temperature sensor of the indoor unit is mounted in the upper sensor holder of the domestic hot water tank.
- The distance between the thermistor cables and power supply cable must always be at least 1.97 inch (5 cm) to prevent electromagnetic interference on the thermistor cables.

Connecting the solar pump station to the indoor unit

Connect the indoor unit terminals as shown on the following figures to the (auxiliary) contact from the solar pump station.

Example

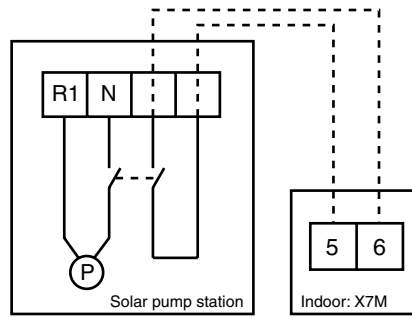

--- Field wiring
 Solar pump station Solar pump station
 Indoor: X7M Indoor: X7M



CAUTION

Make sure that:

- the (auxiliary) contact closes when the pump of the solar pump station operates;
- the (auxiliary) contact opens when the pump of the solar pump station stops;
- the contacts provides the input signal to the indoor unit connection when it is closed;

Connecting the power supply cable from the indoor unit to the domestic hot water tank

Connect the indoor unit terminals to the domestic hot water tank.

Make sure to fix the cables with the cable tie mountings to ensure strain relief.

Connecting the power supply cable from the solar kit to the tank

Refer also to the wiring diagram sticker in the domestic hot water tank switch box.

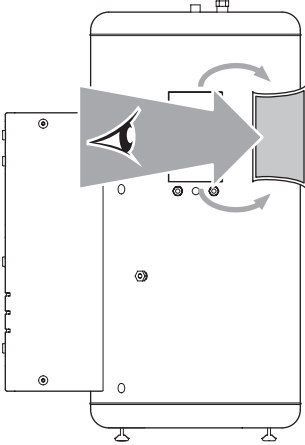

Locate terminal block X8M in the domestic hot water tank switch box and make the required connections:

- from X2M and A4P (option EKR1HB) in the indoor unit to terminal block X8M;
- from the pump of the solar pump station to terminal block X8M.



WARNING

Make sure to connect the earth conductor.

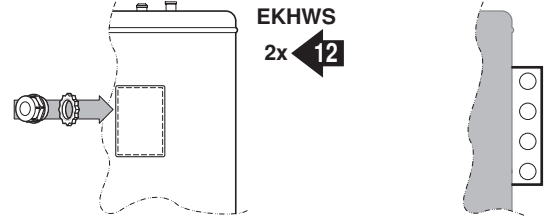

Make sure to ensure strain relief of the cables by correct use of the PG nipples and PG nuts (field supply) (to be mounted on the domestic hot water tank).

Positions where PG nipples and PG nuts need to be screwed in the domestic hot water tank are indicated on figure 1 as actions 14.

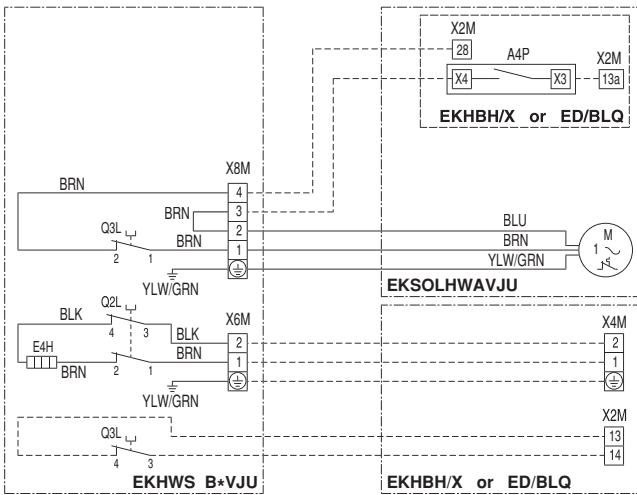
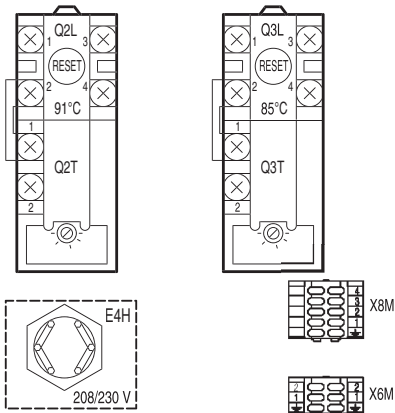

START UP

Commissioning the system before initial start up



CAUTION

Besides the checks before initial start up of the indoor unit (refer to the installation manual of the indoor unit) you must check the following items on the solar kit installation before switching on the circuit breaker:

- The domestic hot water tank is filled with water. Refer to the installation manual of the domestic hot water tank.
- The circuit, connected to the solar kit is filled with water. Refer to the installation manual of the indoor unit.
- The solar collector circuit is filled with glycol. Refer to the installation manual of the solar circuit.
- Make sure the solar kit is properly fixed to the domestic hot water tank and that there are no leaks.
- Ensure the power supply cable from the indoor unit is connected to the domestic hot water tank.
- Mounting of sensors
Make sure the solar panel temperature sensor and the domestic hot water temperature sensor of the solar pump station are properly mounted.
- Ensure that the auxiliary contact of the solar pump station is connected to the indoor unit and will give to the input of the indoor unit when the pump of the solar pump station operates.



WARNING

Field wiring and earthing

Make sure the pump of the solar kit is connected to the domestic hot water tank as shown in the wiring diagram and the pump earth wires have been connected properly. The earth terminals should be tightened.



CAUTION

Verify that following settings are made on the solar pump station:

- Maximum solar panel temperature: $\leq 212^{\circ}\text{F}$ (100°C)
- Maximum tank temperature: 176°F (80°C)
- Minimum temperature difference between domestic hot water tank and solar panel before starting pump operation: $\geq 18^{\circ}\text{F}$ ($\geq 10^{\circ}\text{C}$)

NOTE



Make sure a non-return valve is included in the solar pump station or is installed in the connection line from the solar pump station to the solar kit. Refer also to the general system set-up (on [page 3](#)).

Absence of this valve will cause thermal losses and could cause freezing of the plate heat exchanger.

Checklist for proper functioning

Following items should be checked to assure proper functioning:

- When the temperature of the solar panel becomes 18°F (10°C) higher than the domestic hot water tank temperature, the pump of the solar pump station and the pump of the solar kit will start operation.⁽¹⁾
- When the temperature of the solar panel becomes lower than the domestic hot water tank temperature, the pump of the solar pump station and the pump of the solar kit will stop operation.

(1) Unless the domestic water heating mode is enabled, the solar priority parameter = 1 and the heat pump is heating the domestic water tank at that moment. Refer to "Configuring your system" on [page 12](#) for more information.

Final check

Before switching on the unit, read following recommendations:

- When the complete installation and all necessary settings have been carried out, close all front panels of the unit and refit the indoor unit cover.
- The service panel of the switch box may only be opened by a licensed electrician for maintenance purposes.

OPERATING INSTRUCTIONS

Configuring your system

In order to guarantee maximum energy savings combined with maximum comfort, it is important to configure your system in a proper way.

For this reason, it is strongly recommended to do the following:

Use of schedule timers

- Check the orientation of your solar panel, and find out during what time of the day the intensity of the sun on it is expected to be strong and weak. For example, a solar panel oriented to the east will receive strong intensity during the morning, weak intensity during the afternoon.
- Check your usual pattern of peak domestic hot water consumption. E.g. showering during the morning from 7 to 9 a.m. and again in the evening from 5 p.m. onwards.
- Set the schedule timer for 'domestic water heating' and 'booster heating' as to disable heating of the domestic water tank by the indoor unit before solar radiation on the solar panel can become intensive.

On the other hand, enable 'domestic water heating' and/or 'booster heating' about 1 hour before you usually expect domestic hot water consumption or during night time. In this way, the indoor unit and/or booster heater will heat up the domestic water tank and guarantee domestic hot water in the event there has been no sun.

Example

Your domestic hot water consumption pattern is from 7 a.m. to 9 a.m. in the morning and from 5 p.m. till 11 p.m. in the evening.

Since the solar panel is oriented towards the south-east, the radiation can be intensive on the solar panel from 8 a.m to 6 p.m.

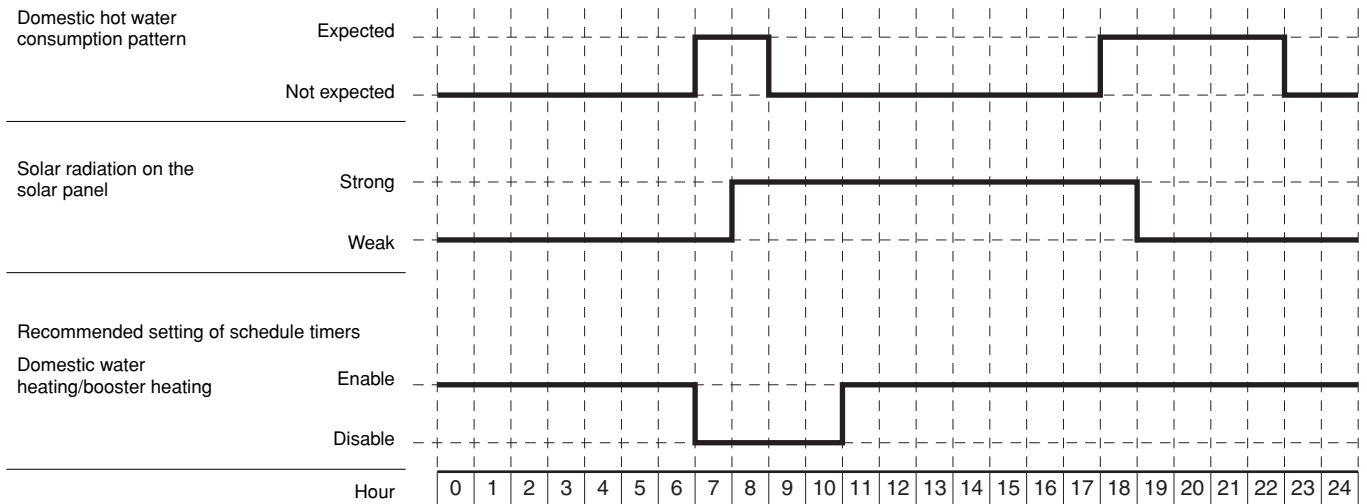

If the domestic hot water tank has not been heated enough by the sun during the day, or a lot of warm water was consumed the evening before, the domestic hot water tank must be heated up during the night time by the indoor unit, so that in the morning domestic hot water is available for consumption. For this reason, in the example above, domestic water heating is enabled during the night, until consumption of warm water is expected to start.

In the morning, the domestic water heating/booster heating is disabled. In this way, the domestic hot water tank is not reheated after or during consumption of warm water and the sun will get the chance to reheat the water as much as possible.

Since domestic hot water consumption is expected again from 5 p.m. onwards, the domestic water heating and/or booster heating is enabled again 1 hour before, from 4 p.m. onwards. This will guarantee, in the case of absence of sun during the day, maximum warm water capacity by 5 p.m.



To set schedule timers, refer to the operation manual of the indoor unit.

Setting of domestic hot water tank temperature

The domestic hot water tank has 2 temperature sensors.

The upper temperature sensor is the thermostat sensor of your indoor unit. This temperature can be set on your indoor unit (refer to the operation manual of the indoor unit). It is advised to set this temperature as low as possible. Start with a low temperature, e.g. 113°F (45°C). If with this temperature you face shortage of warm water during normal tapping patterns, increase gradually until you find the temperature of warm water that covers your daily demand.



WARNING

If this water temperature (domestic hot water tank) can be a potential risk for human injuries, a mixing valve (field supply) shall be installed at the hot water outlet connection of the domestic hot water tank. This mixing valve shall secure that the hot water temperature at the hot water tap never rise above a set maximum value. This maximum allowable hot water temperature shall be selected according to local laws and regulations.



Refer to the operation manual of the indoor unit to change the domestic hot water temperature setting.

The lower temperature sensor is the thermostat sensor of the solar pump station. This temperature can be set on the solar pump station. Put this temperature as high as possible but not higher than 176°F (80°C), as otherwise the thermal protection in the tank might trip.



For optimal solar efficiency and system operation it is advised that domestic hot water temperature setting on the indoor unit controller is lower than the temperature setting on the solar pump station controller.

With above settings, the heating of the water by heat pump/booster heater will be limited to the minimum required, and solar heat will be stocked in the domestic hot water tank to the maximum.

Setting of the solar priority parameter

Simultaneous water heating by the sun and water heating by the heat pump is not possible.

By default, heating of the tank by the heat pump has priority over heating by the sun.

This means that, whenever there is a request of the domestic hot water thermostat and domestic water heating is enabled (by the schedule timer or domestic water heating ON/OFF button, refer to the operation manual of the indoor unit), heating will be done by the heat pump. In case solar heating is busy, solar heating will be stopped.

This is to avoid shortage of domestic hot water in case the solar radiation is very weak, or solar radiation only became high shortly before domestic hot water demand is expected (e.g. on a cloudy day).

This default setting can be changed, so that at all times, when solar heat becomes available, domestic water heating by the heat pump will be (if busy) interrupted and taken over by the sun.

In order to change this, put the field parameter [C-00] to 0. Refer to the installation manual of the indoor unit, paragraph "Field settings" to find out how to access and change field parameters. [C-00] put to 0 means solar priority, [C-01] put to 1 means heat pump priority.



Be aware that setting this parameter to 0 might cause insufficient warm water at the time of domestic hot water demand during days with weak solar intensity.

If you are not sure about the availability of hot water, check the domestic hot water temperature on the controller (see operation manual of the indoor unit) and if too low, push the 'booster domestic hot water' button. This will trigger domestic water heating by the heat pump immediately.

 The booster heater in the domestic hot water tank can work independent from the solar heating or domestic water heating by the heat pump.

For a detailed decision flow on domestic water heating by solar kit or by heat pump, and/or booster heater, refer to the annexes "Decision flow of heating the domestic water by heat pump or by solar kit" on page 15 and "Decision flow of heating the domestic water by booster heater" on page 16.

TROUBLESHOOTING AND SERVICING

This section provides useful information for diagnosing and correcting certain troubles which may occur with the unit.

This troubleshooting and corrective actions may only be carried out by your local Daikin technician.

General guidelines

Before starting the troubleshooting procedure, carry out a thorough visual inspection of the unit and look for obvious defects such as loose connections or defective wiring.

WARNING

When carrying out an inspection on the switch box of the unit, always make sure the main switch of the unit is switched off.

When a safety device was activated, stop the unit and find out why the safety device was activated before resetting it. Under no circumstances safety devices may be bridged or changed to a value other than the factory setting. If the cause of the problem cannot be found, call your local dealer.

DANGER

Do not touch water pipes during and immediately after operation as the pipes may be hot. Your hand may suffer burns. To avoid injury, give the piping time to return to normal temperature or be sure to wear proper gloves.

WARNING

Do not touch the internal parts (pump, etc.) during and immediately after operation.

Your hands may suffer burns if you touch the internal parts. To avoid injury, give the internal parts time to return to normal temperature or, if you must touch them, be sure to wear proper gloves.

General symptoms

Symptom 1: The pump of the solar pump station starts operation, but the pump of the solar kit is not working.

POSSIBLE CAUSES	CORRECTIVE ACTION
The tank has reached its maximum allowed temperature (see the temperature reading on the indoor unit display)	Refer to "Maximum tank temperature" on page 4.
The auxiliary contact from the solar pump station to the indoor unit is not properly wired	Check the wiring. Make sure that when the solar pump station pump is operating, the indoor connection receives the input signal.
The pump of the solar kit is not properly wired to the indoor unit through the tank	Check the wiring.
The priority for domestic water heating is given to the heat pump	Refer to "Setting of the solar priority parameter" on page 13.
The thermal cut out of the tank has operated	Refer to error code RR in "Error codes" on page 14.

Symptom 2: There is a lot of sun intensity but the solar pump station and solar kit pumps do not start.





POSSIBLE CAUSES	CORRECTIVE ACTION
The maximum temperature of the domestic hot water tank is reached	Check the domestic hot water temperature on the controller of the indoor unit (refer to the operation manual of the indoor unit) and check the maximum temperature setting on your solar pump station.
The outdoor unit is heating up the domestic water tank, since the priority for domestic water heating is given to the heat pump	Refer to "Setting of the solar priority parameter" on page 13.

Error codes

When a safety device is activated, the user interface LED will be flashing, and an error code will be displayed.

Following error codes might be related to a malfunction of your solar system. First, check also the corrective actions as mentioned in the installation manual.

Reset the safety by turning the unit OFF and back ON.

Instruction to turn the unit OFF			
User interface mode (heating/cooling )	Domestic water heating mode ()	Push the  button	Push the  button
ON	ON	1 time	1 time
ON	OFF	1 time	—
OFF	ON	—	1 time
OFF	OFF	—	—

In case this procedure for resetting the safety is not successful, contact your local dealer.

Error code	Failure cause	Corrective action
BH	Outlet water temperature of indoor unit too high (>149°F (>65°C))	Check the 3-way valve and its wiring: <ul style="list-style-type: none"> • 3-way valve is broken or wrongly connected and remains in the 'domestic hot water' position during operation of the solar kit. • One of the non-return valves in the solar kit is broken. Check the non-return valves.
RR	Booster heater thermal protector is open	The maximum allowed temperature setting on the solar pump station is set too high. (shall be set below 176°F (80°C)). Reset the booster heater thermal protector on the domestic hot water tank.

DISPOSAL REQUIREMENTS

Dismantling of the unit, treatment of the refrigerant, of oil and of other parts must be done in accordance with relevant local and national legislation.



Your product is marked with this symbol. This means that electrical and electronic products shall not be mixed with unsorted household waste.

Do not try to dismantle the system yourself: the dismantling of the system, treatment of the refrigerant, of oil and other parts must be done by a qualified installer in accordance with relevant local and national legislation.

Units must be treated at a specialized treatment facility for re-use, recycling and recovery. By ensuring this product is disposed off correctly, you will help to prevent potential negative consequences for the environment and human health. Please contact the installer or local authority for more information.

TECHNICAL SPECIFICATIONS

• Maximum operating pressure of the connections to and from the solar pump station	362.60 psi (2.5 MPa)
• Maximum operating pressure of the connections to and from the indoor unit and connections to and from the domestic hot water tank heat exchanger	43.51 psi (0.3 MPa)
• Minimum/maximum ambient temperature	39.2/95°F (4/35°C)
• Minimum/maximum fluid temperature	33.8/212°F (1/100°C)
• Heat transfer liquid (solar side)	propylene glycol

ANNEXES

Decision flow of heating the domestic water by heat pump or by solar kit

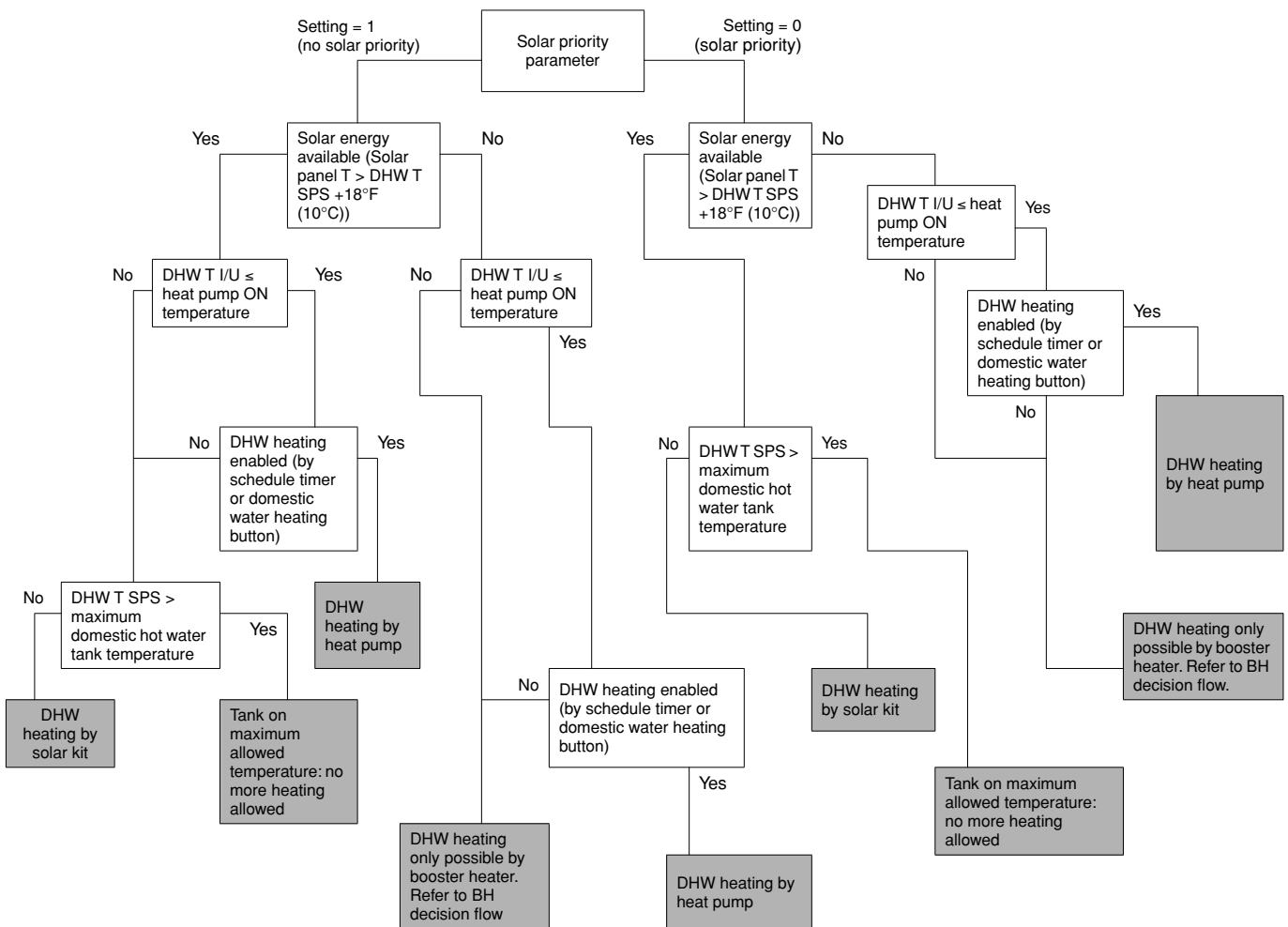

- DHW** Domestic Hot Water
- DHW T SPS** Domestic Hot Water Temperature by the Solar Pump Station temperature sensor
- DHW T I/U** Domestic Hot Water Temperature by the Indoor Unit temperature sensor
- BH** Booster Heater

Decision flow of heating the domestic water by booster heater

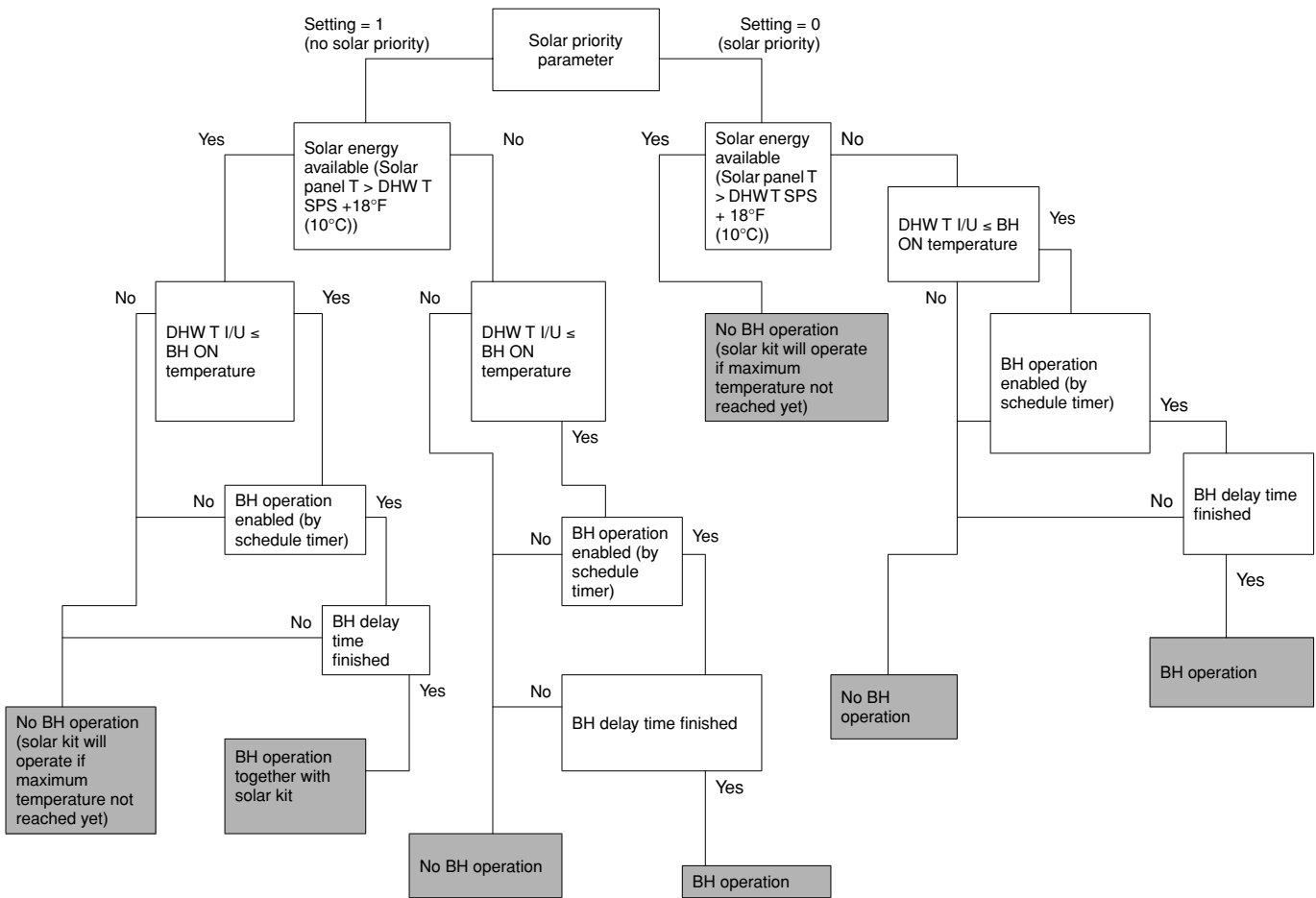

- DHW** Domestic Hot Water
- DHW T SPS** Domestic Hot Water Temperature by the Solar Pump Station temperature sensor
- DHW T I/U** Domestic Hot Water Temperature by the Indoor Unit temperature sensor
- BH** Booster Heater

NOTES

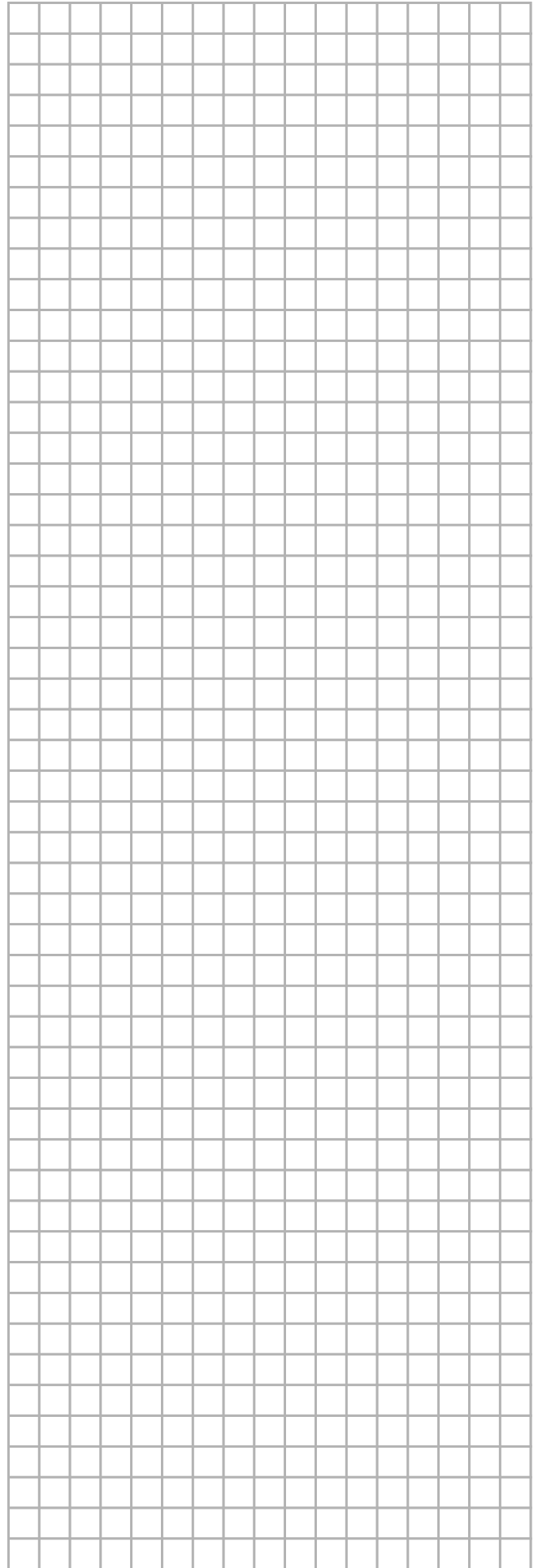



4PW54234-1 0000005

Copyright © Daikin

DAIKIN AIR CONDITIONING AMERICAS

1645 Wallace Drive, Suite 110
Carrollton, TX 75006

DAIKIN EUROPE N.V.

Zandvoordestraat 300, B-8400 Oostende, Belgium



4PW54234-1